

Instruction Manual for TUMAX® DSL286AF series

Thank you for purchasing TUMAX products.

This is an innovative designed electronic flash for both digital cameras and film cameras. The features are leading photography into digital era. Advanced technology is used in the flash to control the correct amount of light output. Please kindly take few minutes to read the instruction manual before using.

Digital TTL / Auto Focus flash for:

- C** - Canon Digital E-TTL, E-TTL II cameras & E-TTL film cameras
- N** - Nikon Digital TTL, i-TTL cameras & TTL, i-TTL film cameras
- OP** - Olympus & Panasonic Digital TTL cameras
- P** - Pentax Digital P-TTL & film cameras
- SA** - Sony Alpha & Minolta Digital ADI, D Lenses cameras & TTL film cameras

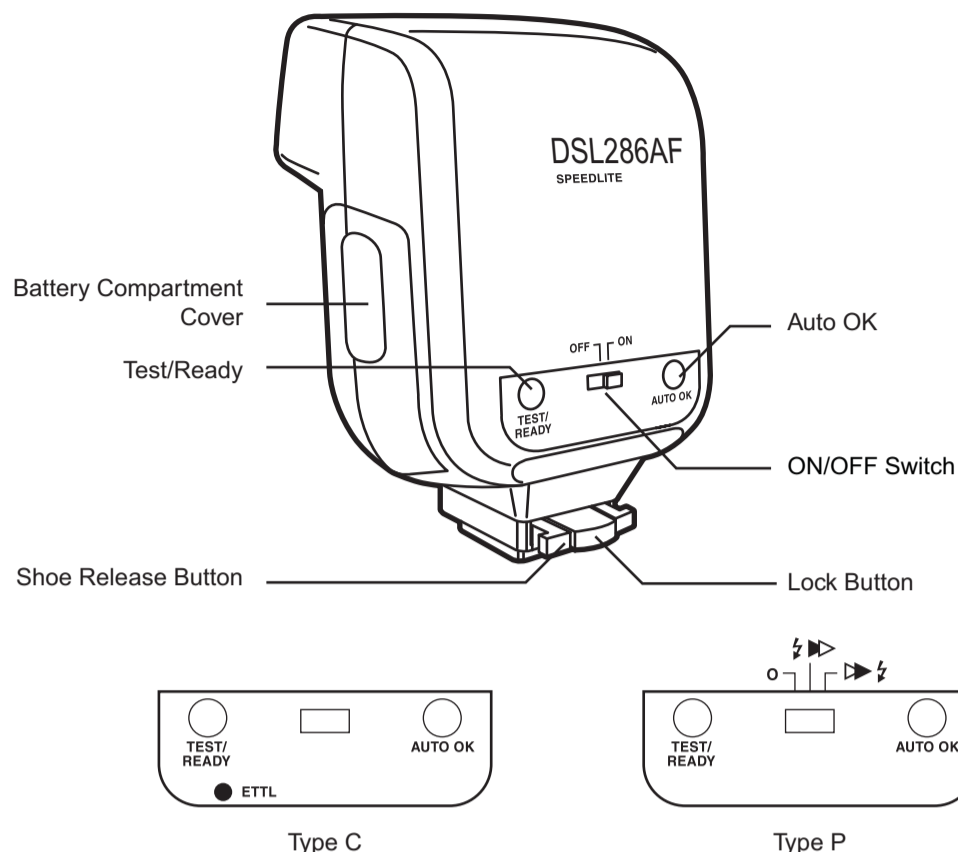
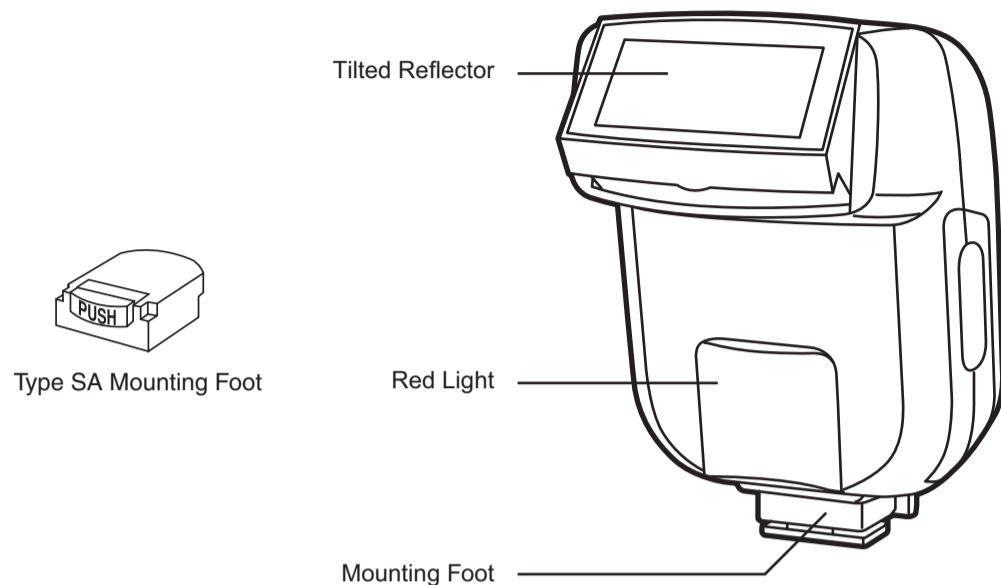

CHARACTERISTICS

- Red focus assist beam for low light focusing
- Automatic shutter speed setting
- Flash readiness indication
- Five position tilted reflector
- Red-eye reduction (Type N, OP and P)
- Front and rear curtain synchronization
- Power saving function

SPECIFICATIONS

Guide Number (ISO 100)	18(m)/59(ft)
Five Position Tilted Reflector	0°/45°/60°/75°/90°
Power Source	2 x 1.5V AA size batt. (R6, LR6)
Flash Duration	1/2,000 - 1/40,000 sec.
Recycling Time	0.3 - 10 sec. with fresh batteries
Number of Flashes	100 times with fresh batteries
Dimensions	Approx. 65 - 54 - 98mm
Weight w/o batt.	Approx. 127 g

Specifications are subject to change without notice.

INSERTING THE BATTERIES

- Turn the ON/OFF switch to OFF position.
- Slide the battery compartment cover to open.
- Insert 2 AA batteries according to the indicated battery symbols.
- Close the battery compartment cover.

Caution: When loading batteries make sure of the correct polarities. Mixed up battery poles may cause damage to the flash unit. Replace all batteries once at a time and make sure that the batteries are of the same brand and type with the same capacity.

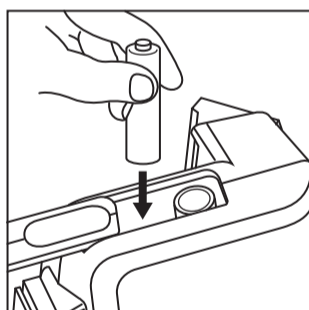

MOUNTING FLASH TO THE CAMERA

- For Type C, N, OP and P flash: Release the Lock button. Insert the mounting foot of the flash unit into the camera's accessory shoe clip. Press the Lock button to fasten the flash unit to your camera.
- For Type SA flash: Insert the mounting foot of the flash unit into the camera's accessory shoe. Then the flash unit is locked in place.

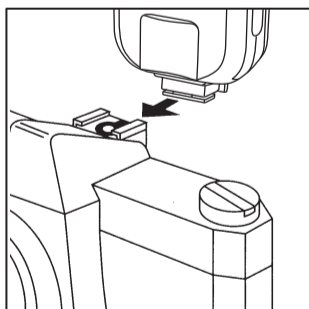

REMOVING THE FLASH

For Type C, N, OP & P flash: Press both sides of the Shoe Release button towards the direction indicated by the narrow symbols. Then remove the flash backwards.

For Type SA flash: Push the Shoe Release button and pull the flash off backwards.

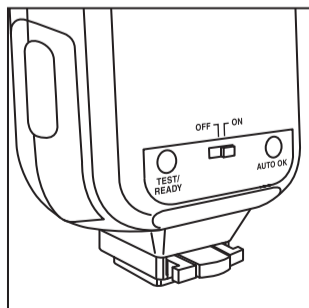

OPERATING THE FLASH AND TESTING

Slide the ON/OFF switch to the "ON" position. After a few seconds the Test/Ready lamp should glow, thereby indicating that the flash is ready to shoot. Press the Test/Ready button to make sure that your flash works properly. If the flash discharges, wait until the Ready lamp glows again.

Adjust your camera to the appropriate setting. Most cameras can be set to the program position (See your camera's manual for details on flash synchronization.) When the flash is ready to fire, it will automatically match the camera's shutter speed. The flash readiness indicator will appear on the camera. Different camera models indicate flash readiness in different ways (see your camera's manual).

Point the digital camera at the subject and focus. Gently press the shutter button on the digital camera to check the image. Then press the shutter button firmly. The Auto OK indicator will light when the picture is exposed correctly.

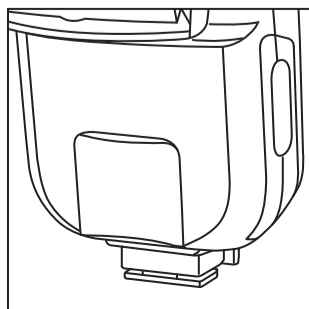

AF / TTL OPERATION

AF - AUTO FOCUS

If the camera is compatible with an external AF mode, then slightly press the shutter button, the focus assist light is automatically activated to help the camera focus properly when the subject is in darkness.

TTL

The flash performs pre-flashes for cameras to calculate the intensity of flash light output. Therefore the flash light output is controlled automatically.

-For Nikon D40 & D40x owners: The flash can support an ISO speed up to 800 in full auto mode. It may not perform as expected if the ISO speed exceeds the supported range.

RED-EYE REDUCTION (Type N, OP and P)

Red-eye reduction function reduces the red-eye phenomenon by emitting pre-flashes before the main flash. To setup this function, please refer to the camera instruction manual.

FRONT AND REAR CURTAIN SYNCHRONIZATION

Some cameras offer the option of rear curtain synchronization (Rear mode) triggering the flash unit at the end of the exposure time. Rear curtain synchronization is particularly advantageous when using slow shutter speeds (slower than 1/30 sec.) or when shooting moving objects that have their own source of light. Rear curtain synchronization gives a more realistic impression of movement because the light streaks behind the light source instead of building up in front of it, as is the case when the flash is synchronized with the front shutter curtain. Depending on its operation mode, the camera uses shutter speeds slower than its sync speed.

For Type P flash: You could select the synchronization mode as either front curtain (⚡➡) or rear curtain (➡⚡) at the back of the flash. The flash will fire according to the mode selected to match with the camera shutter.

For Type C, N, OP, SA flash: The camera controls front or rear curtain synchronization, therefore no setting is required to be done on the flash.

Note: The rear curtain synchronization is only possible on cameras with this feature. See your camera's instruction manual for details.

BOUNCE PHOTOGRAPHY

Using direct flash to illuminate a subject will result in harsh, unnatural and unattractive shadows. This can be avoided by bounce flash. The head of our flash can be tilted to an angle of 45°, 60°, 75°, or 90°. You can tilt the flash head to bounce the light off the ceiling or walls. While shooting indoor, this technique can help to create more natural-looking pictures of people with softer shadows.

In order to have your pictures correctly exposed using bounce flash, the following is recommended to users:

- (1) Select white or reflective surfaces to bounce the light off. Otherwise your pictures will come with an unnatural color cast similar to that of the reflecting surface.
- (2) Set the camera's exposure mode to Aperture Priority Auto ("A") or Manual ("M").
- (3) Use a wider aperture than normally do, as 2 or 3 stops of light can be lost when using bounce flash.

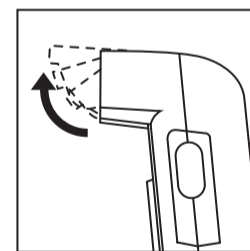

POWER SAVING FUNCTION

If there is no communication between the flash and the camera for around 3 minutes, the flash will automatically be switched to power saving mode in order save battery power. The Ready light will be off while in power saving mode.

To reactivate the flashgun, simply press your camera's shutter or switch the main switch off and on again.

The flashgun is not completely switched off in power saving mode. However, power consumption is drastically reduced. If you are not going to use your flashgun for a while, we recommend you to turn the flash off.

HINTS FOR MAINTENANCE AND BETTER FLASH PHOTOGRAPHY

- When not in use, switch the unit off. Take the batteries out when the flash is being stored or when it will be carried for a long time. Keep your flash away from dust and moisture to prolong its life.
- The flash should not be exposed to dripping or splashing.
- Batteries should not be exposed to excessive heat such as sunshine, fire or the like.
- Never try to open or repair your flash since the electronic circuit inside carries a high voltage. If your flash needs repair or does not work properly, please return it to the place of purchase.

